

Sysmac: A fully integrated platform

One connection - One software - One machine controller

FACTORY AUTOMATION

HMI · Programming · DB connection · IT systems



MACHINE CONTROL

Servo · Inverter · I/O · Safety · Vision · Robotics · Sensing

Omron provides tailored solutions

Flexible and integrated production business models

In today's globalized manufacturing environment, diverse and complex challenges arise and need to be overcome. The global market rapidly changes, and manufacturing companies are under increasing pressure to supply products in a timely manner that satisfy a wide variety of consumer needs. Omron industrial automation makes efficient, flexible and cost effective manufacturing possible.



Innovation

- New technology for smart manufacturing
- Collaboration between humans and machines
- Environmentally safe products



Productivity

- Integrated systems for optimized manufacturing
- Production data available in real-time
- In-line quality inspection: zero defects



Flexibility

- Quick product changeovers
- Openness and third party connectivity
- Scalable systems for optimum solutions



Reliability

- Non-stop processes, 24/7 operation
- Extended product lifecycle



Globalization

- Products meet global standards
- Local support for training, repairs and spare-parts supply
- Engineering environment compliance with global standards

- ✓ Through automation, **Omron** supports the advancement of manufacturing and contributes to a sustainable society by providing environmentally safe products

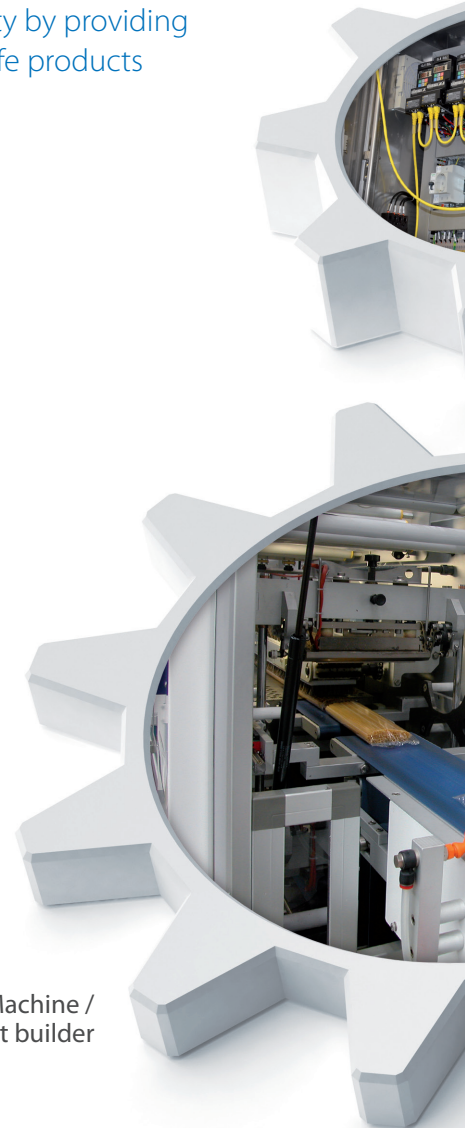

Machine /
Equipment builder

- ✓ The **Sysmac** technology platform ensures a flexible and integrated production business model

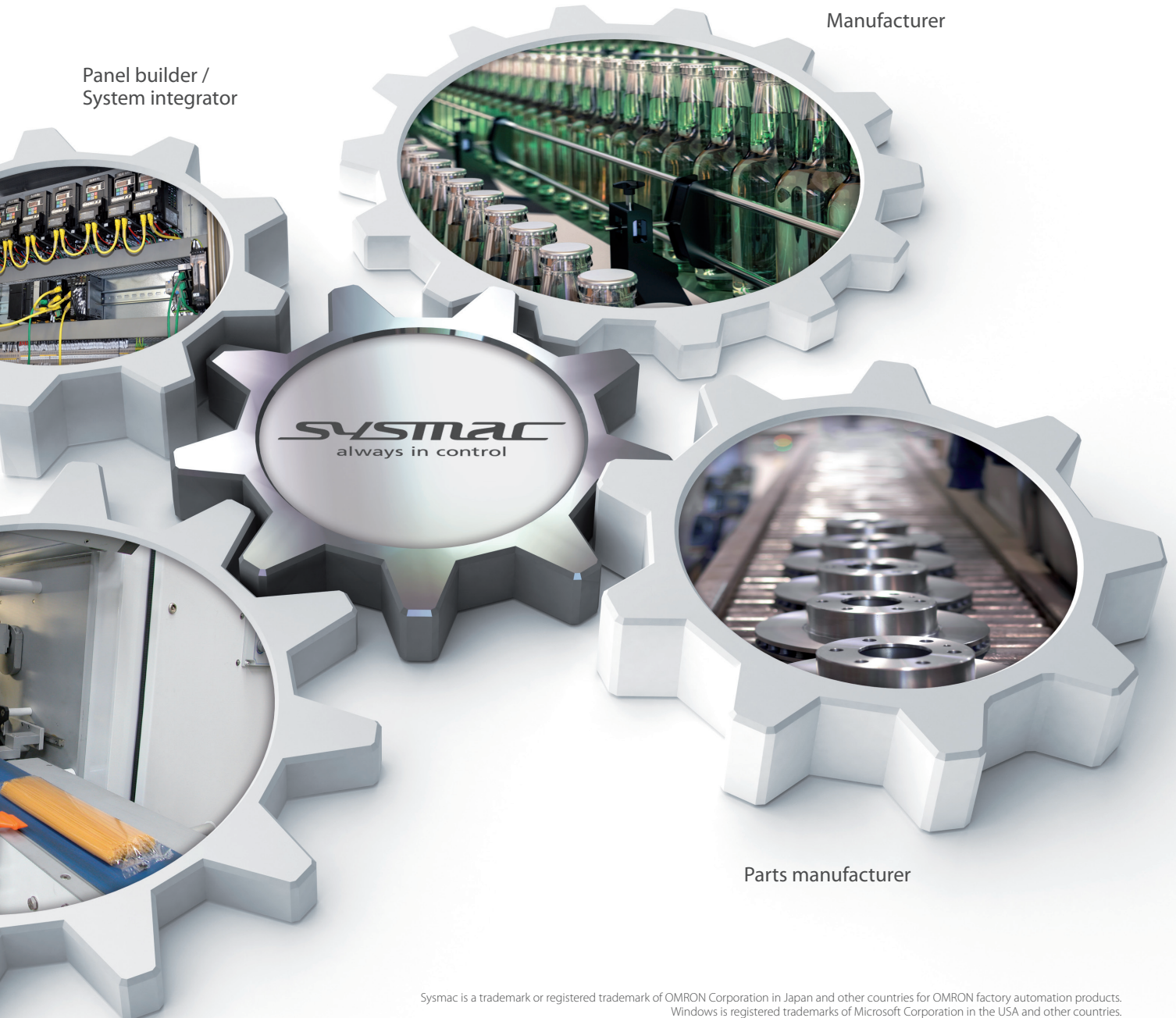

Sysmac: A fully integrated platform

Integration and Functionality

Sysmac is an integrated automation platform dedicated to providing complete control and management of your automation plant. At the core of this platform, the Machine Controller series offers synchronous control of all machine devices and advanced functionality such as motion, robotics and database connectivity. This multidisciplinary concept allows you to simplify solution architecture, reduce programming and optimize productivity.



FACTORY
AUTOMATION

MACHINE
CONTROL

Machine Automation Controller

Motion

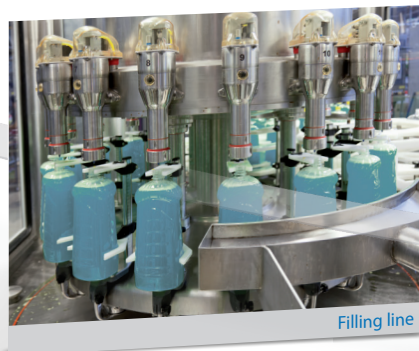

Filling line

- Motion Control: Integrated within the IDE, and operating in real-time
- Standard PLCopen Function Blocks plus Omron generated motion FB's
- Direct Synchronous control for Position, Speed and Torque

Safety



Assembly

- All safety related data is synchronized with the whole network
- Safety functions such as muting, guard locking, EDM and valve monitoring are simple to manage

- ✓ **One Integrated Development Environment software** for Configuration, Programming, Simulation and Monitoring

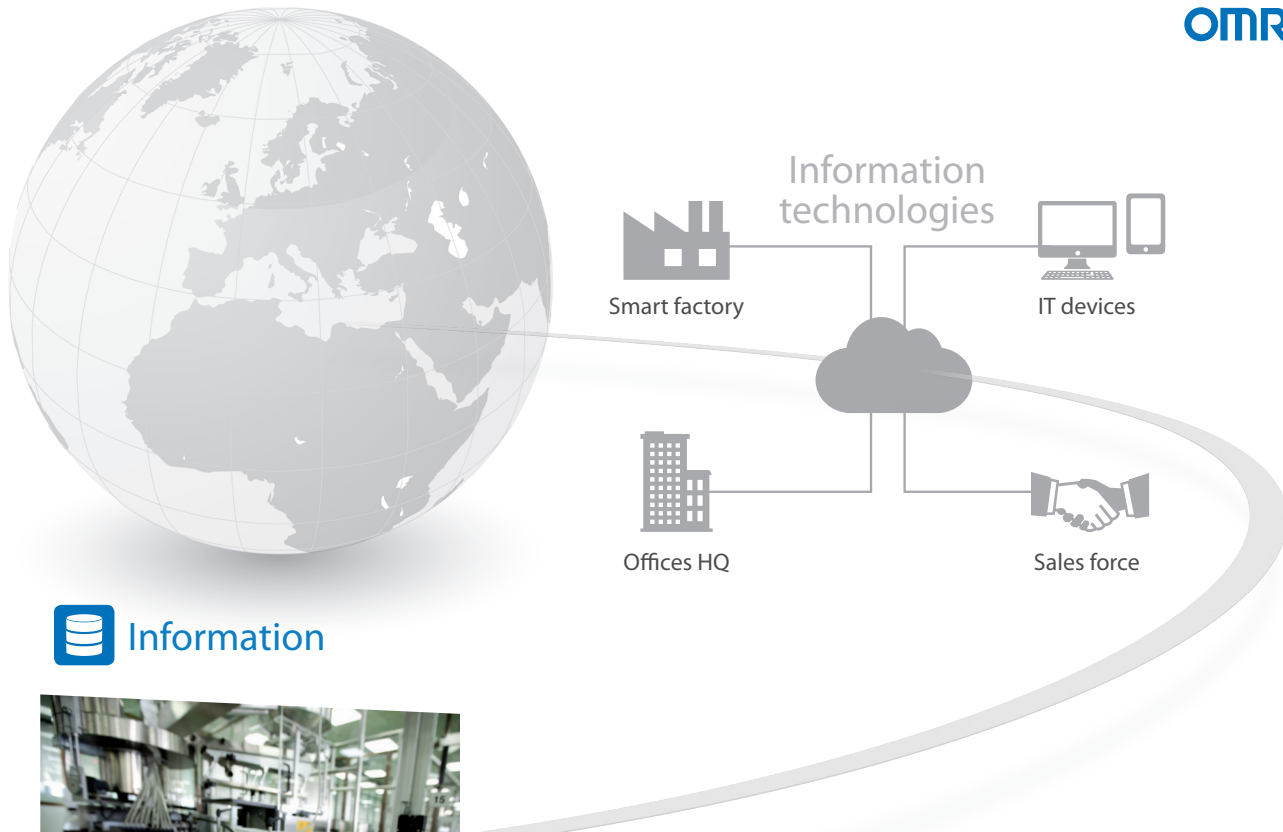

 Information



- Sysmac communicates in real-time with Databases such as SQL
- Secure Data: In the event of a server going down or losing communications, data is automatically stored in internal memory
- Sysmac operates with Databases at high speed [1000 table element/ 100 ms] ensuring realistic Big Data Processing to improve productivity and aid predictive maintenance etc.

- ✓ **Integrated Automation Control:**
The Sysmac platform is scalable and provides the performance and functionality for a wide range of solutions from simple machines through to manufacturing cells

 Vision



- Higher resolution images available without increasing the vision processing time
- Shape search technology: Provides more stable and accurate object detection for Pick & Place projects

 Robotics



- Up to 8 Delta robots with one controller
- Time-based Robotic Function Blocks make programming easier

 Sensing

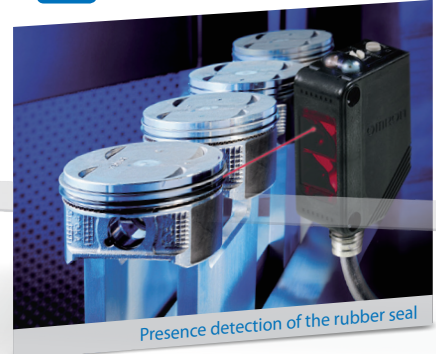

- Full control of the process parameter setting and predictive maintenance functions
- High precision detection and positioning data synchronized on the network

One Connection

Seamless machine control and factory automation

One machine control through one connection and one software is how we define the Sysmac automation platform. The Machine Automation Controller integrates logic, motion, safety, robotics, vision, information, visualization and networking under one software: Sysmac Studio. This one software provides a true Integrated Development Environment (IDE) that also includes a custom 3D motion simulation tool. The machine controller comes standard with built-in EtherCAT and EtherNet/IP. The two networks with one connection purpose is the perfect match between fast real time machine control and data plant management.

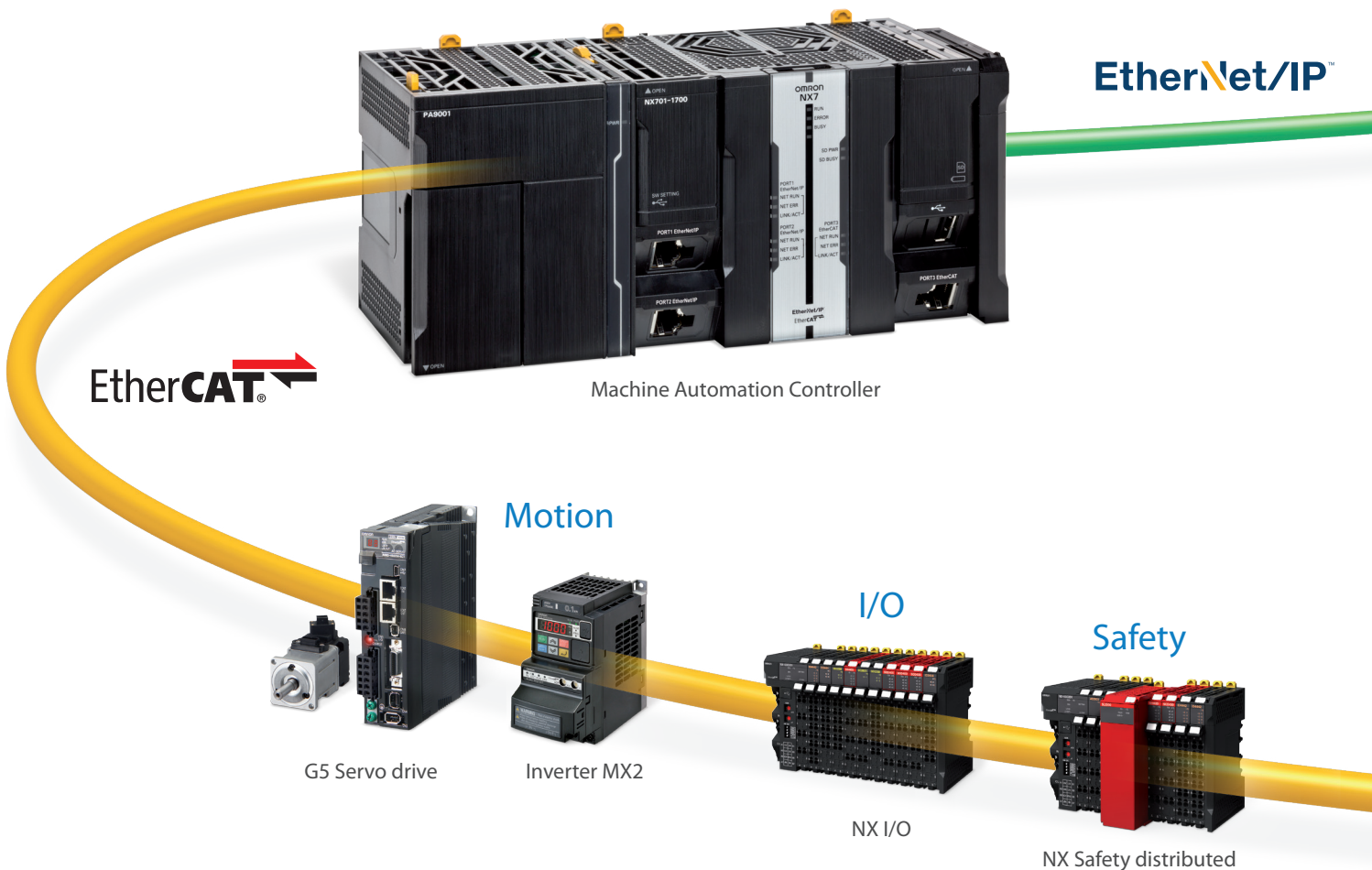

EtherCAT - Machine Control

- Fastest cycle time: 125 μ s
- Up to 256 synchronized axes
- 512 slaves
- Embedded in Omron servo drive, inverter, I/O, Safety, Vision and Sensing
- Uses standard STP Ethernet cable with RJ45 connectors

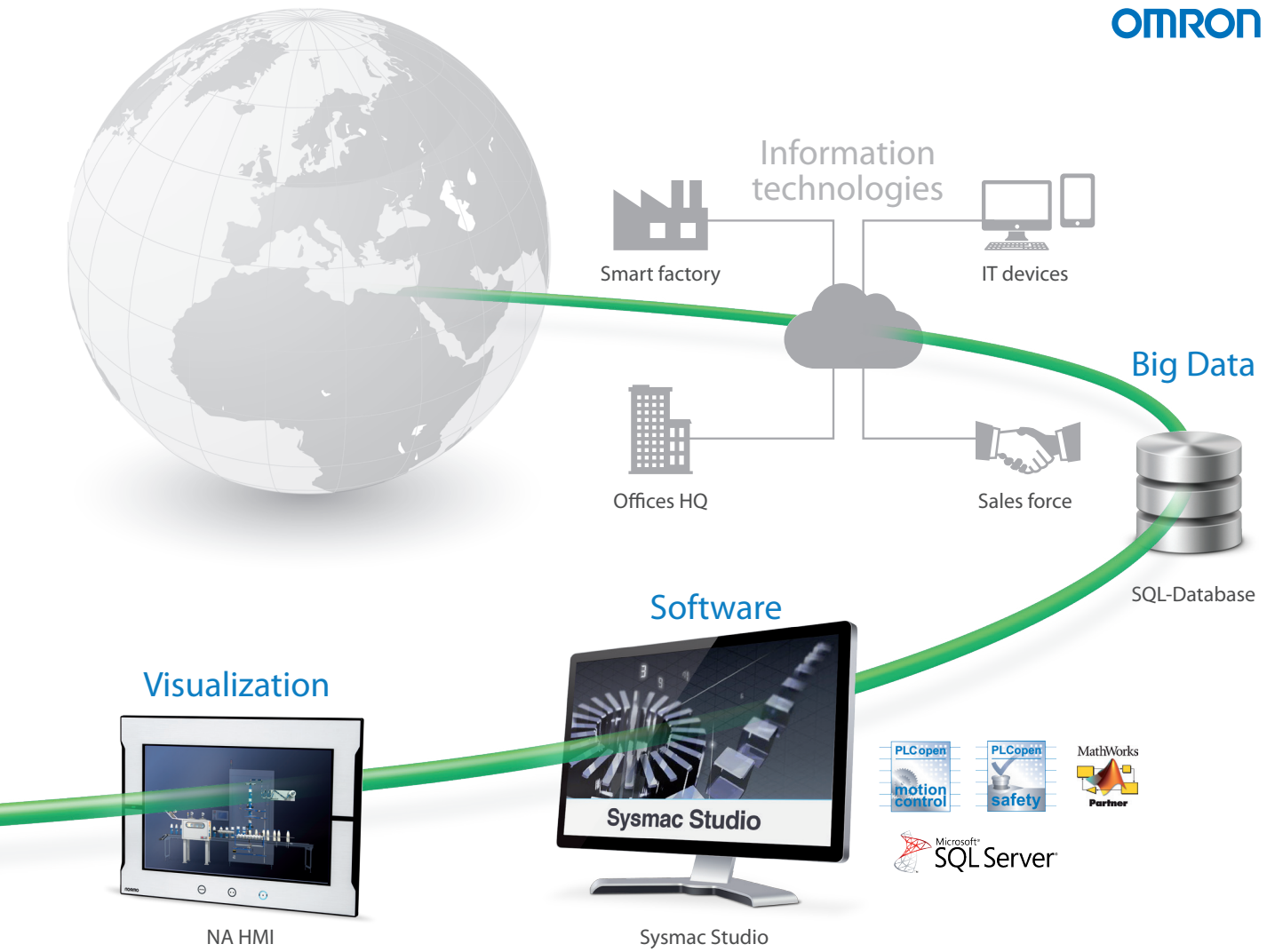

Ethernet - Factory Automation

- Peer-to-Peer controller communication
- Interface with Sysmac Studio , NA HMI or SCADA software
- Database connection for Microsoft SQL Server, Oracle, IBM DB2, MySQL and Firebird
- FTP server

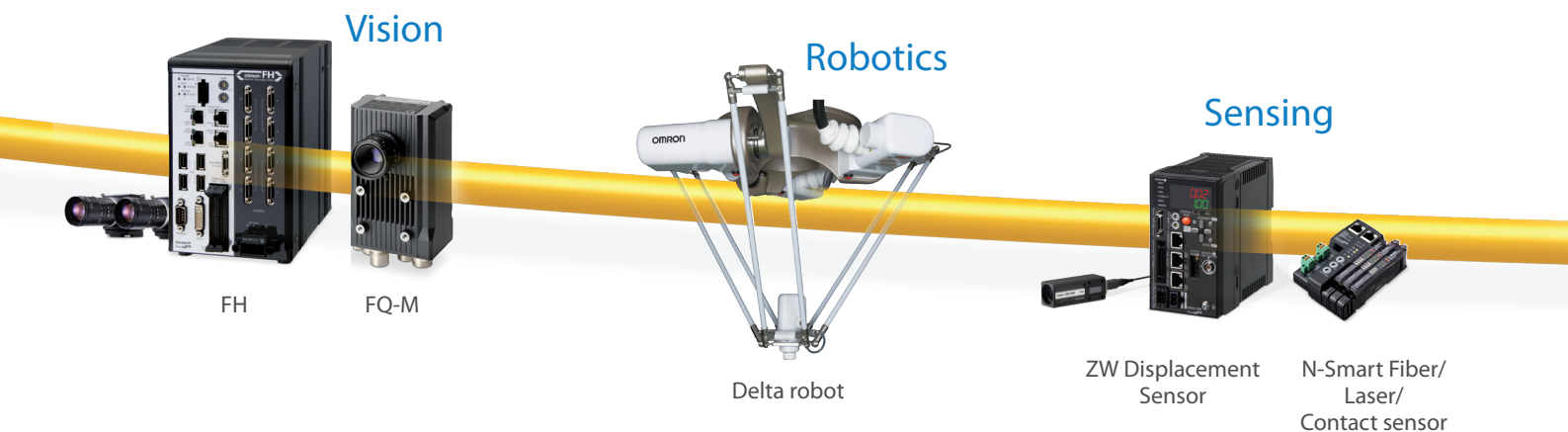

One Software

One Integrated Development Environment Software

Created to give you complete control over your automation system, Sysmac Studio integrates configuration, programming and monitoring. Graphics-oriented configuration allows quick set-up of the controller, field devices and networks while machine and motion programming based on IEC standard and PLCopen Function Blocks for Motion Control cuts programming time. Smart Editor with On-line debugging helps quick and error free programming. Advanced simulation of sequence and motion control, and data trace reduce machine tuning and set-up.

Programming

Multi-tasking and fully compliant with IEC 61131-3 standard. The program editor includes smart support functions such as syntax error check and clear color segregation of variables and symbols. ST instructions can be directly written in Ladder programs thanks to in-line ST function.

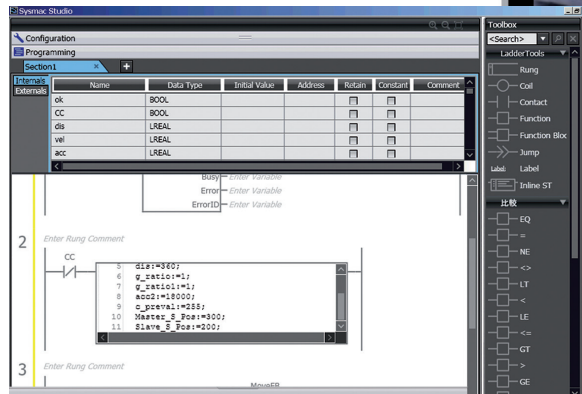

Motion control

The graphical CAM editor allows quick implementation of complex motion profiles. CAM tables can be modified on the fly. A PLCopen Function Blocks for the Motion Control library are available to implement general purpose motion control.

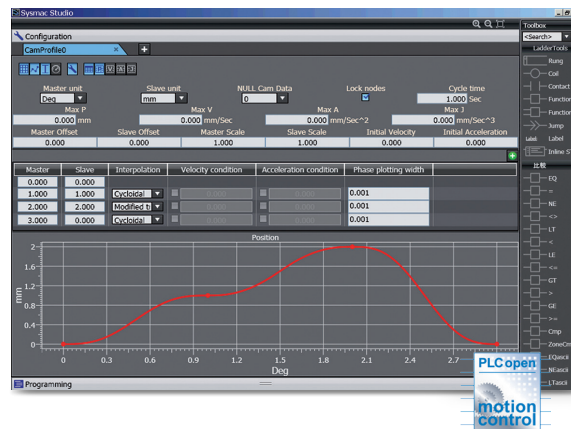

Safety

The Function Block Diagram editor includes 46 safety FB/FN. Conforms with IEC 61131-3 standard programming and PLCopen Function Blocks for Safety.

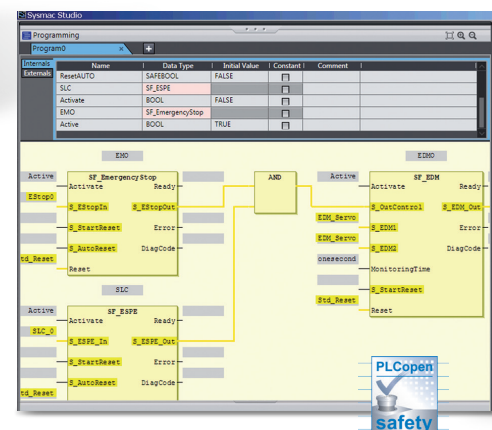

Information

Projects can generate a huge volume of data, but thanks to the Sysmac Database Connectivity FB library, this data can be analyzed and acted on in real-time.

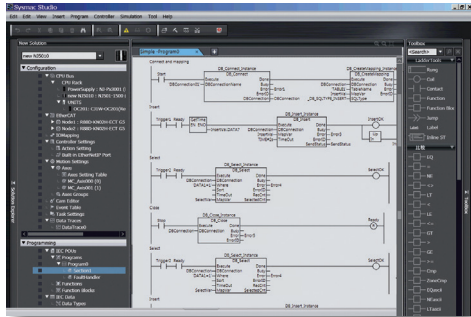

Simulation

Motion trajectories in 3D can be pre-tested with advanced simulation of sequence and motion control. Simulation of single Function Blocks, POU's (Program Organization Unit) or the entire program can be performed. In addition all standard features such as Break & Step are available.

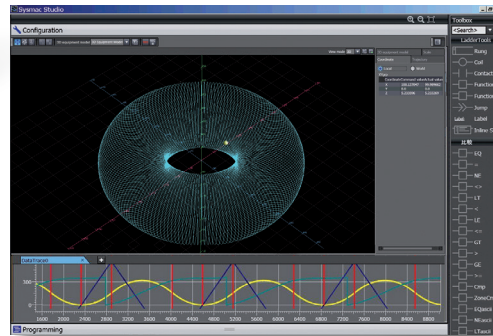

Studio

HMI

Design your own IAG's (Intelligent Application Gadgets) using the machine parts collection. It is also possible to embed code within an IAG using VB.net standard functionality. The Simulator in the Sysmac Studio allows you to test the NA application with the Machine Controller program.

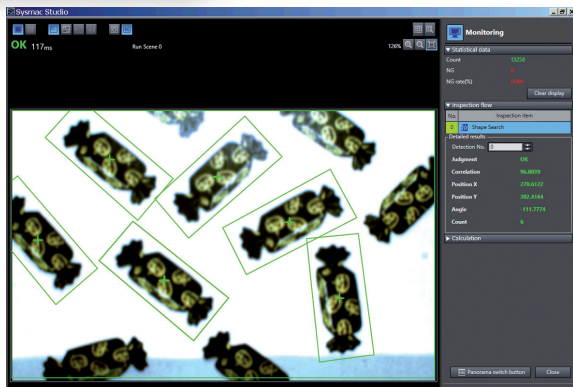
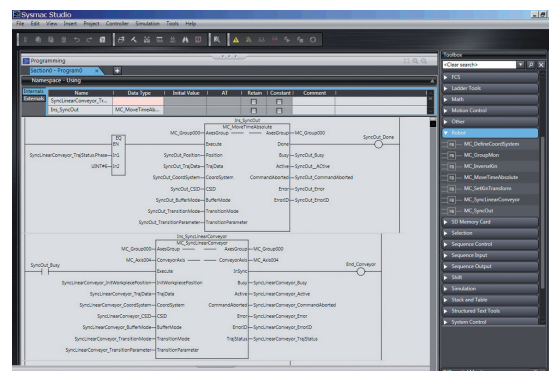
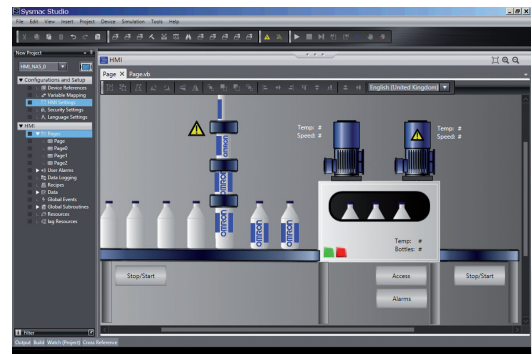

Vision

Just drag & drop any processing items to build a program for image processing.

Robotics

Integrated robotics Function Block library for Delta 2 and Delta 3 control. A 3D simulator is also integrated in the Sysmac Studio, visualizing and reproducing the Delta robot trajectory.

One Machine Controller

Complete and robust machine automation

The Machine Automation Controller is at the heart of the Sysmac platform. One integrated machine controller that offers speed, flexibility and scalability of software centric architecture without compromising on the traditional reliability and robustness that you have come to expect from Omron PLCs. The Machine Controller is designed to meet extreme machine control requirements in terms of motion control speed and accuracy, communication, security and robust system. You just create...



Application libraries

- FB library option for packaging engineering (Rotary Knife, Winder/Unwinder, Temperature Control...)

System robustness

- One event log for controller, field devices and networks
- Standard PLC system check: Watch-Dog Timer, memory check, network topology check, etc.

Machine automation controller features

- Fastest system cycle: 125 μ s
- Up to 256 synchronized axes
- Synchronized control of all machine network devices
- Multi-tasking programs
- In-line ST, Structured Text and Ladder mixed in the same program
- Full control of Axes Group Position
- System Backup and Restore
- Built-in EtherCAT and EtherNet/IP ports
- CE and cULus global standards



Hardware design

- Architecture based on new Intel CPU
- The most compact controller in its class
- Built-in USB port and SD card slot

✓ Scalability, performance, robustness... Choose the most suitable CPU for your application!



	NX7	NJ5	NJ3	NJ1
Fastest Cycle Time	125 μ s	500 μ s	500 μ s	1 ms
Real axes	256 axes	64 axes	8 axes	2 axes
EtherCAT slaves	512	192	192	64
Motion Core	Two synchronized Motion Cores	Synchronized Motion Core	Synchronized Motion Core	Synchronized Motion Core



EtherNet/IP™

Standard Factory network

- Programming
- Other Machine controllers
- HMI / SCADA
- IT systems
- Standard Protocols and Services: TCP/IP, FTP, NTP, SNMP
- CIP protocol
- Database connection FB's for Microsoft SQL Server, Oracle, IBM DB2, MySQL and Firebird
- Built-in SECS/GEM communications functionality

EtherCAT®

Standard Machine network

- Servos
- Inverters
- Robotics
- Vision systems
- Distributed I/O
- Integrated Safety
- Sensing

Standard programming

- Fully conforms with IEC 61131-3 standards
- PLCopen Function Blocks for Motion Control



NA HMI Series

The next generation of machine interface

An HMI that is dynamic, intuitive and predictive makes industrial machines more attractive and competitive. The new Omron HMI enables faster, more efficient control and monitoring - and a more natural, proactive relationship between operator and machine. The design has been based on real applications and customer requirements, a future-proofed, scalable platform that will evolve with their ever-changing needs, allowing real time reaction to events. As part of the system family, the NA Series is fully aware of the total machine.

Hardware design

- Architecture based on Intel
- Fan-less cooling
- Water and dust proof design – IP65
- SD card slot for transfer/store projects and data logging



Connectivity

- 3 x USB ports: USB memory and programming
- 2 x Ethernet ports: for machine network / IT systems and programming

NA machine interface features

- Architecture based on Intel
- Widescreen models: 7, 9, 12 and 15 inches
- 1280 x 800 high resolution display
- One integrated project in the Sysmac Studio: NX7/NJ Controller, Safety, Vision and Machine interface

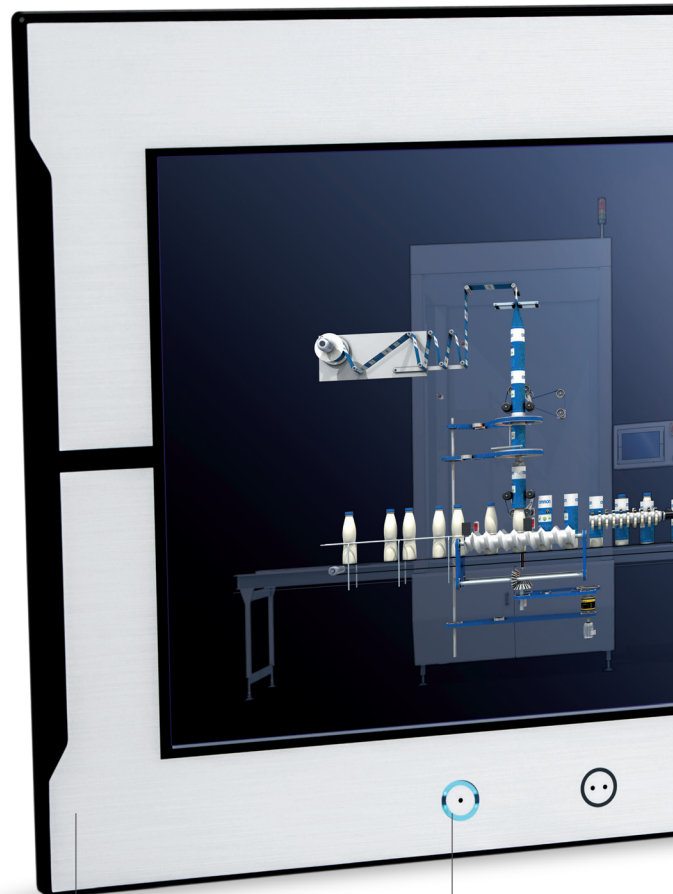

Black and Silver frame color

Programmable Function Keys



Scalable solution

- Display size from 7-inch up to 15-inch
- Widescreen in all models
- 1280 x 800 resolution for the 12-inch and 15-inch models
- 800 x 480 resolution for the 7-inch and 9-inch models
- Available in black and silver frame colors

Machine interface

- Touch screen
- 3 x Programmable Function Keys
- Multimedia including PDF files and video

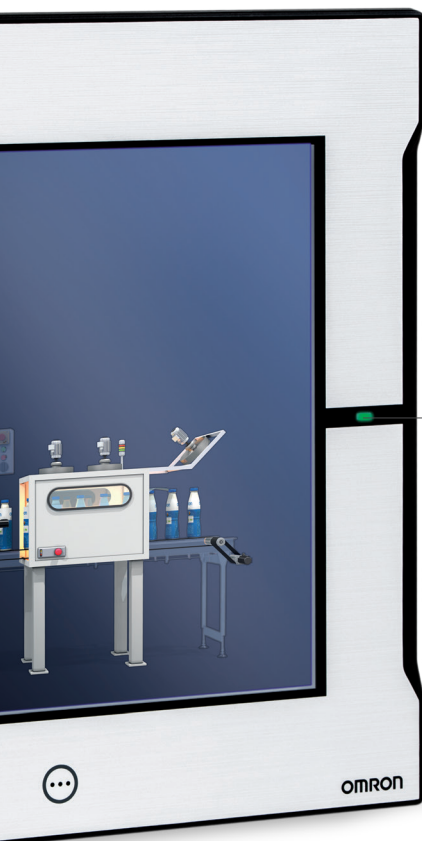

RUN/ERR led indicator

IAG – Intelligent Application Gadgets

- Graphics collection from the machine parts
- Embedded code within an IAG with the VB.net standard functionality
- Make your own IAG collection and share them between projects, like a Function Block

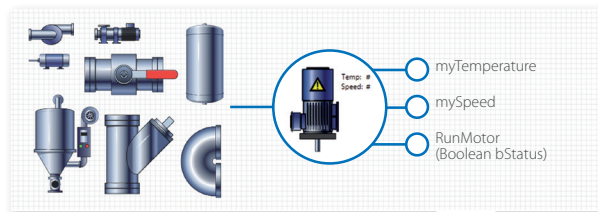

Sysmac Studio

- NA HMI programming as a device in the Sysmac Studio
- NX7/NJ controller variables (Tags) in the NA project
- Multiple-access level security with password protection
- Visual Basic programming with VB.net
- NA application testing with the NX7/NJ program via the Simulator in the Sysmac Studio

NX I/O

Speed and accuracy for machine performance

Based on an internal high-speed bus running in synchronization with the EtherCAT network and using the time-stamp function, the NX I/O can be controlled with microsecond accuracy and with nanosecond resolution. The I/O range consists of over 90 models including position control, temperature inputs and integrated safety.



EtherCAT connectivity

- Distributed clock to ensure I/O response with less than 1 μ s jitter
- Safety over EtherCAT (FSoE)

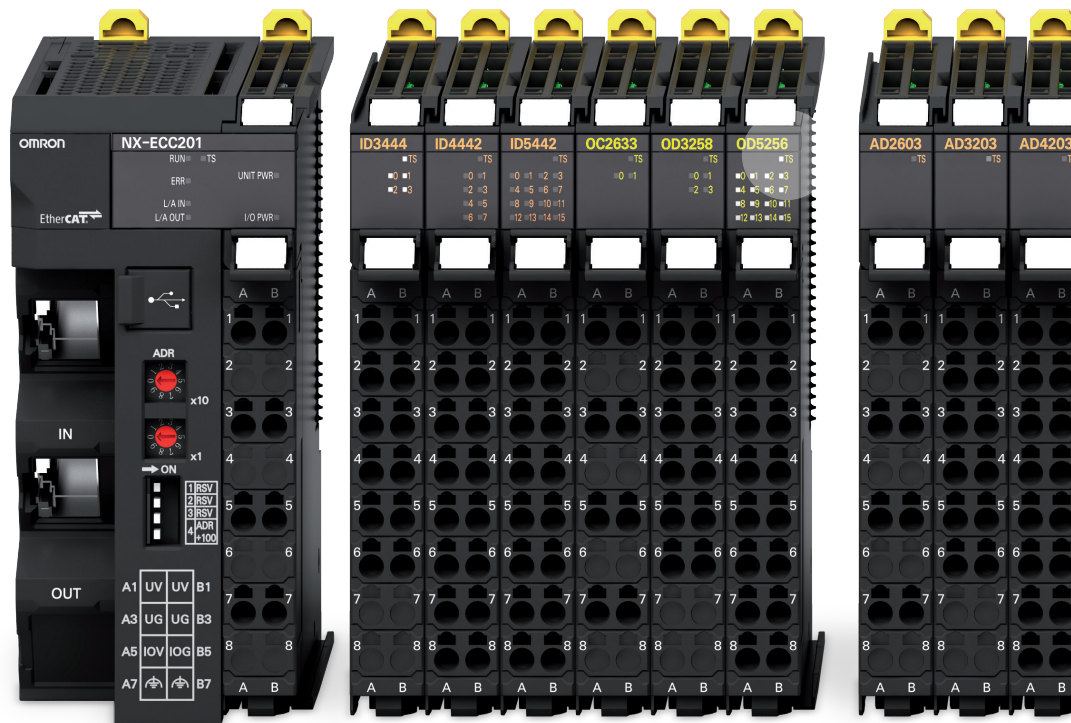

EtherCAT coupler

- Up to 1024 byte input / 1024 byte output
- Automatic backup/restore of all I/O unit parameters. Except Safety Control unit and Safety I/O units

Digital I/O

- Units for 4, 8 or 16 points
- Standard, high-speed and time-stamp models
- Relay outputs, NO only or NO+NC
- 240 V AC inputs
- 16- and 32-point units with MIL connector

NX I/O features

- NsynX technology provides deterministic I/O response with nanosecond resolution
- Digital I/O: high-speed and time-stamp models (NsynX)
- Analogue I/O: high performance models offer 10 μ s conversion time per channel and 1:30000 resolution
- Detachable front connector with push-in type screwless terminals on all NX I/O units
- On/Offline configuration, simulation, and unified troubleshooting in the Sysmac Studio software

Serial communication

- Units for RS232C or RS422A/485 serial communication interface

- High signal density; up to 16 I/O points in 12 mm width



NsynX technology

- The NsynX technology is provided by the internal high-speed bus synchronized with the EtherCAT network. This technology is designed for machine control and includes:
 - I/O units with distributed clock
 - High-speed I/O units synchronized with the EtherCAT cycle
 - I/O units with Time-Stamp function (accuracy < 1 μs)

Time Stamp sequence example

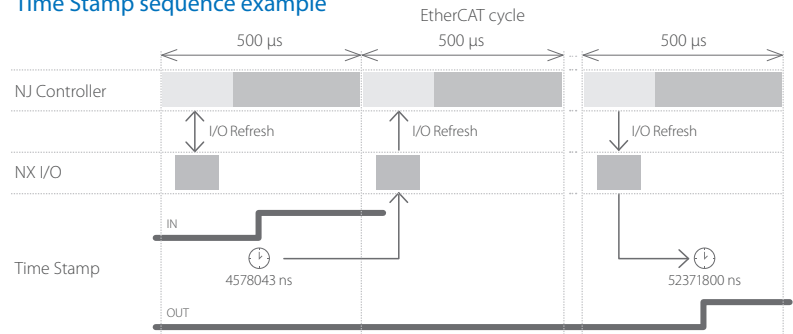

Accurate control of input events and perfect control of output with nanosecond resolution

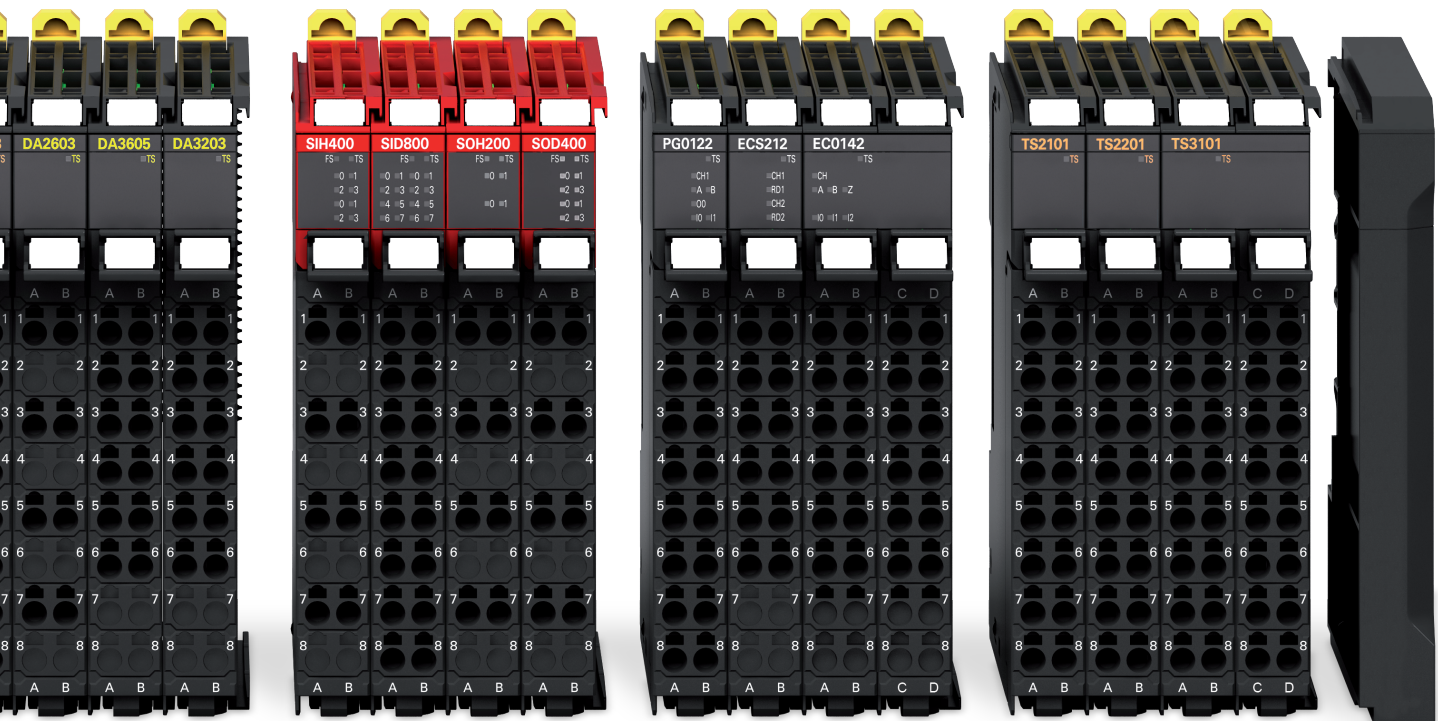

Analogue I/O

- +/-10V voltage and 4-20 mA current signals
- 2, 4 or 8 channels per input unit
- 2 or 4 channels per output unit
- Standard and high-performance models

Safety I/O

- Up to 8 safety input points per unit
- Freely allocation of the Safety I/O units on the internal high speed bus.

Position interface

- Encoder input units for connection of external axes to the Sysmac system
- Incremental and absolute encoder support
- Positioning control unit with pulse train output

Temperature Inputs

- Thermocouple or RTD inputs, 2 or 4 per unit

End Cover

- Fast and secure screwless push-in connections
- Removable I/O connectors for easy pre-wiring, testing and system maintenance

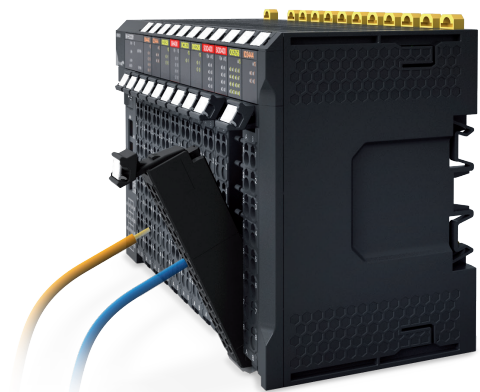

NX Safety distributed

Integrated safety into machine automation

The Sysmac platform integrates a safety solution within our one connection and one software concept. One connection is realized through the use of Safety over EtherCAT -FSoE- protocol. The One software is achieved by using the Sysmac Studio for configuration, programming and maintenance. The NX safety system consists of safety controller and safety I/O units. Both the safety controller and safety I/O can be freely distributed in an I/O rack throughout the network, mixing them in any combination with standard NX I/O.

EtherCAT®



EtherCAT telegram



Safety over
EtherCAT®

NX Safety controller

- The safety controller variables are part of the NX7/NJ controller project
- Flexibility and reusability of the programming code

NX Safety features

- The safety controller meets PLe according to the ISO 13849-1 and SIL3 according to IEC 61508
- Flexible system lets you freely mix safety controller and safety I/O units with standard NX I/O
- Integration in One software, Sysmac Studio
- Certified programs can be reused, which reduces the amount of verification work



Functional
Safety
Type
Approved

www.tuv.com
ID 060000000

ISO 13849-1, PLe

IEC 61508, SIL3

Safety integration in One software

- Integrated Development Environment in Sysmac Studio provides one common software for hardware configuration, programming and maintenance of the Sysmac platform
- 46 safety FB/FN conforming with IEC 61131-3 standard programming
- PLCOpen Function Blocks for safety



Machine Automation Controller

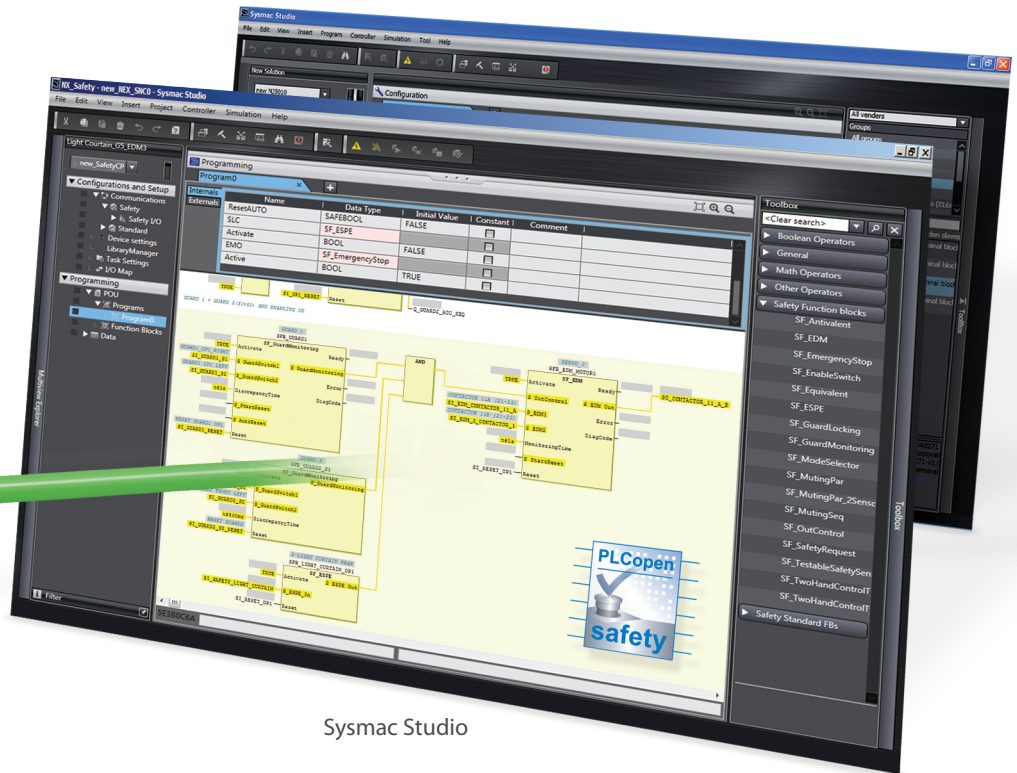

Sysmac Studio

Safety over EtherCAT frame



NX Safety I/O

- Up to 8 safety input points per unit
- High connectivity I/O units for direct connection to a variety of devices
- I/O data monitoring in the NX7/NJ controller project

G5 Servo system

At the heart of every great machine

Great machines are born from a perfect match between control and mechanics. G5 gives you that extra edge to build more accurate, faster, smaller and safer machines.



EtherCAT connectivity

- Compliant with CoE -CiA402 Drive profile-
- Cyclic Synchronous Position, Velocity and Torque modes
- Embedded Gear Ratio, Homing and Profile Position mode
- Distributed clock to ensure high precision synchronization



Safety conformance

- PL-d according ISO 13849-1
- STO: IEC61800-5-2
- SIL2 according to EN61508

G5 servo system features

- Compact size servo drives with EtherCAT connectivity built-in
- High-response frequency of 2 kHz
- Load vibration suppression
- Embedded Safety conforming ISO 13849-1 Performance Level d
- Advanced tuning algorithms (Anti-vibration function, torque feedforward, disturbance observer)
- Wide range of linear and rotary servo motors



Improved rotary motors

- Low cogging torque servo motors
- High accuracy provided by 20 bit encoder
- Motors and connectors with IP67
- Large range of motors from 0.16 Nm up to 96 Nm nominal torque (224 Nm peak)
- Standard and high inertia motors

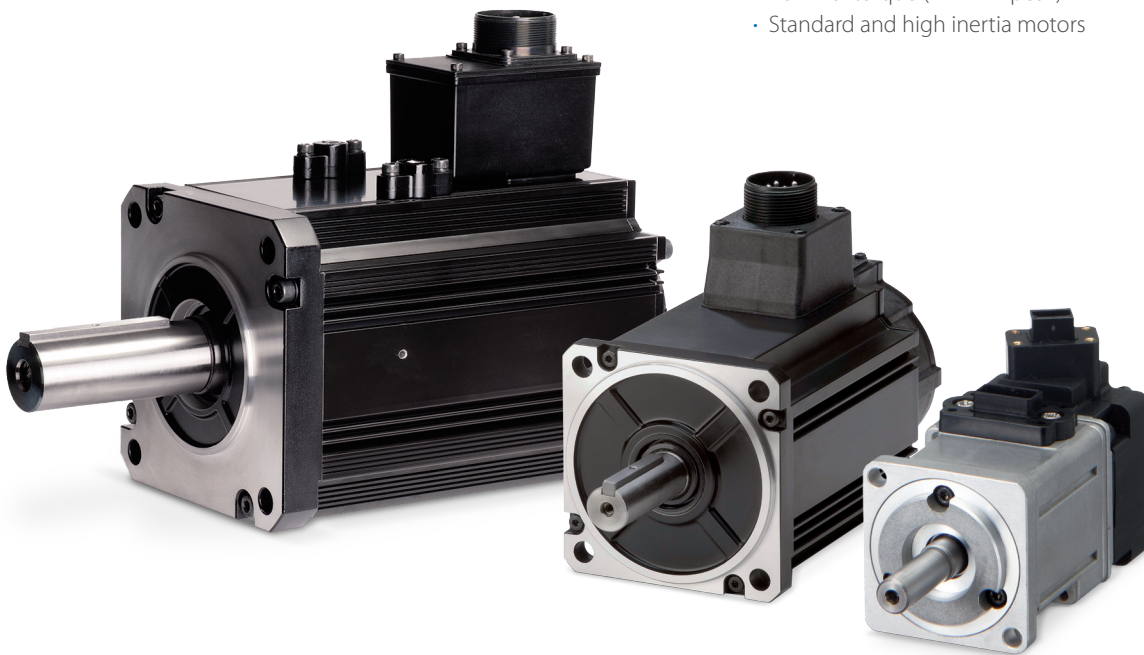

Ironless linear motors

- Compact, efficient design
- Excellent force-to-weight ratio
- No latching force

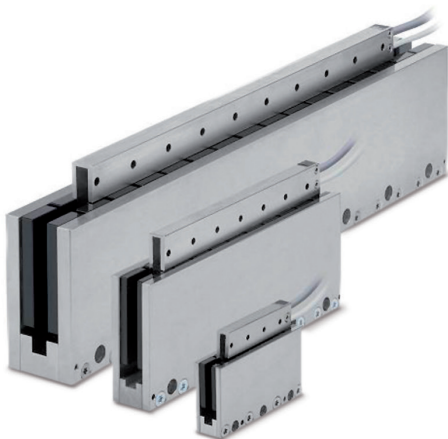

Iron-core linear motors

- Compact, flat design
- Optimum ratio between force and volume
- Weight-optimized magnetic track

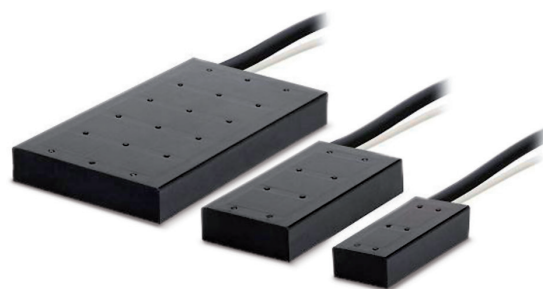

MX2 and RX Inverter series

Drive solution for machine automation

Thanks to its advanced design and algorithms, the MX2 inverter provides smooth control down to zero speed, plus precise operation for cyclic operations and torque control capability in open loop. The RX series combines high performance, application functionality and customisation to match the precise requirements. Both, the MX2 and RX inverter series are fully integrated within the Omron Sysmac automation platform.

Torque control in open loop

- Ideal for low to medium torque applications
- Can replace a flux vector inverter or servo drive in suitable systems

Quick response to load fluctuation

- Stable control without decreasing machine speed improves quality and productivity

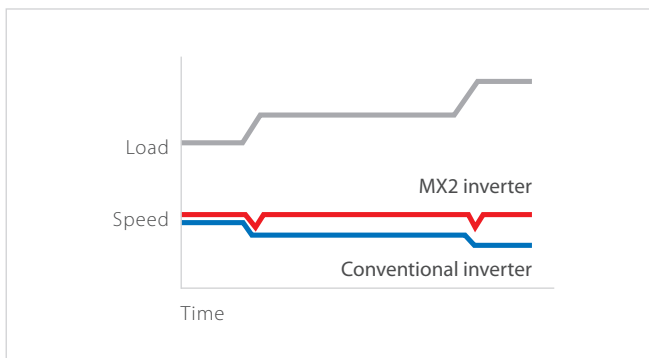

EtherCAT

MX2

MX2 features

- Power range up to 15 kW
- Torque control in open loop, ideal for low to medium torque applications
- 200% starting torque near stand-still operation (0.5 Hz)
- Double rating VT 120%/1 min and CT 150%/1 min
- IM and PM motor control
- Drive Programming software tool
- 24 VDC backup supply for control board and communications
- Built-in application functionality (i.e. Brake control)



EtherCAT

RX

Motor efficiency control

- Double rating VT 120%/1 min and CT 150%/1 min
- Energy saving function

200% starting torque

- Near stand-still operation
- High starting torque in open loop
- Control of fast cyclic loads

(Example of Speed vs. Torque Characteristics: RX series type)

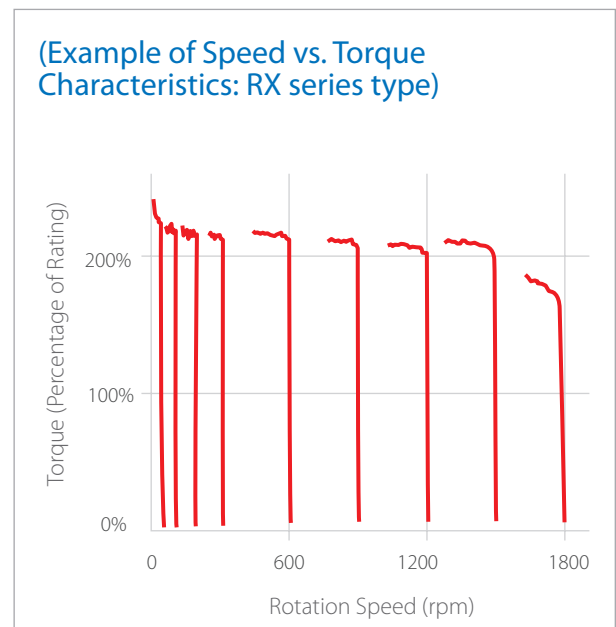

RX features

- Power range up to 132 kW
- Sensor-less and closed-loop vector control
- High starting torque in open-loop (200% at 0.3 Hz)
- Full torque at 0 Hz in closed-loop
- Double rating VT 120%/1 min and CT 150%/1 min
- Drive Programming software tool
- Built-in application functionality (i.e. ELS - Electronic Line Shaft-)

FQ-M Vision sensor

Designed for object tracking

The FQ-M series is a vision sensor designed specifically for pick and place applications. It comes with EtherCAT embedded and can be configured and monitored from Sysmac Studio software. The FQ-M series is compact, fast and includes an incremental encoder input for easy tracking and calibration.

Advanced shape search technology



Varying material ie. shiny

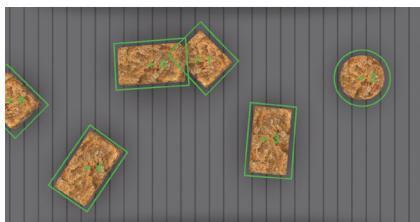

Overlapping products



Product detection:
10 pcs with rotation < 200 ms

Detection

- Up to 5000 pieces per minute with 360 degree rotation
- Stable and robust detection under changeable environmental conditions

Design

- Camera and image processing in one
- Standard C-mount lenses; choose the field of view and focus distance you need
- Variety of industrial connector types (angled, straight) for correct mounting
- EtherCAT port for object tracking
- Ethernet port for advanced configuration and monitoring
- Vision sensor with encoder input for tracking function

Software tool

- Fully integrated within the Sysmac Studio software tool
- Intuitive and icon driven set-up and configuration
- Trending and logging function



FH Vision system

Flexible solution for machine vision

The FH vision system is optimized to detect the position and orientation of any object at high speed and with high accuracy. The built-in EtherCAT communications enable reliable and easy networking with motion control, increasing the overall machine performance. A flexible machine vision tailored for quality inspection.

Flexible machine vision

- Over 100 processing items including 1D code, 2D code and OCR
- Inspection of scratches and defects

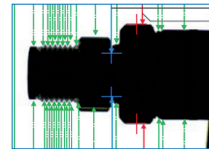

Dimension check



Character and code reading

Multiple inspection

- Powerful 4-core i7 parallel processor
- Up to 8 camera by one controller

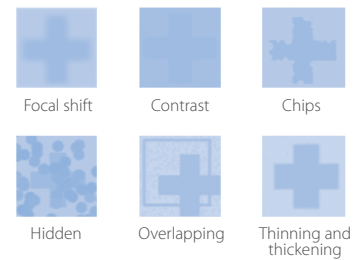
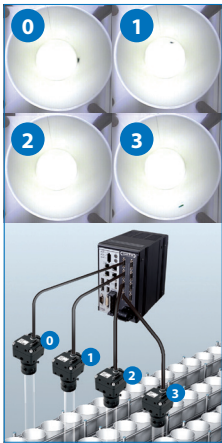

Advanced shape search technology

- Differences of the work piece
- Dust and dirt conditions
- Detection of overlapping objects
- Changing ambient environment



Wide camera range

- Up to 12 Mpixel
- High speed CMOS camera
- Use different fields of vision and at any angle



ZW Measurement Sensor

Ultra-compact, Lightweight sensor measures any material

The ZW confocal fiber displacement sensor delivers stable, non-contact in-line measurements of height, thickness and other dimensions. It solves the problems of traditional laser triangulation sensors: deviation between different material with inclination tolerance. The compact sensing head has no electronic parts to eliminate problems of installation space and mutual interference, electrical/magnetic noise, temperature rise and mechanical positioning. The EtherCAT interfaces integrates height and position coordinates for profile mapping.

- Ultra-compact sensing head: 24x24mm weighs only 105g
- High flexibility fiber optic cable from sensor to controller - up to 32m
- Mount sensing head one time - no need to re-tune for changing materials
- Separate amplifier provides white LED light source, spectroscope and processor to convert reflected color light to distance
- Stable measurements for any material - glass, stainless steel, mirror, white ceramic and PCB substrates

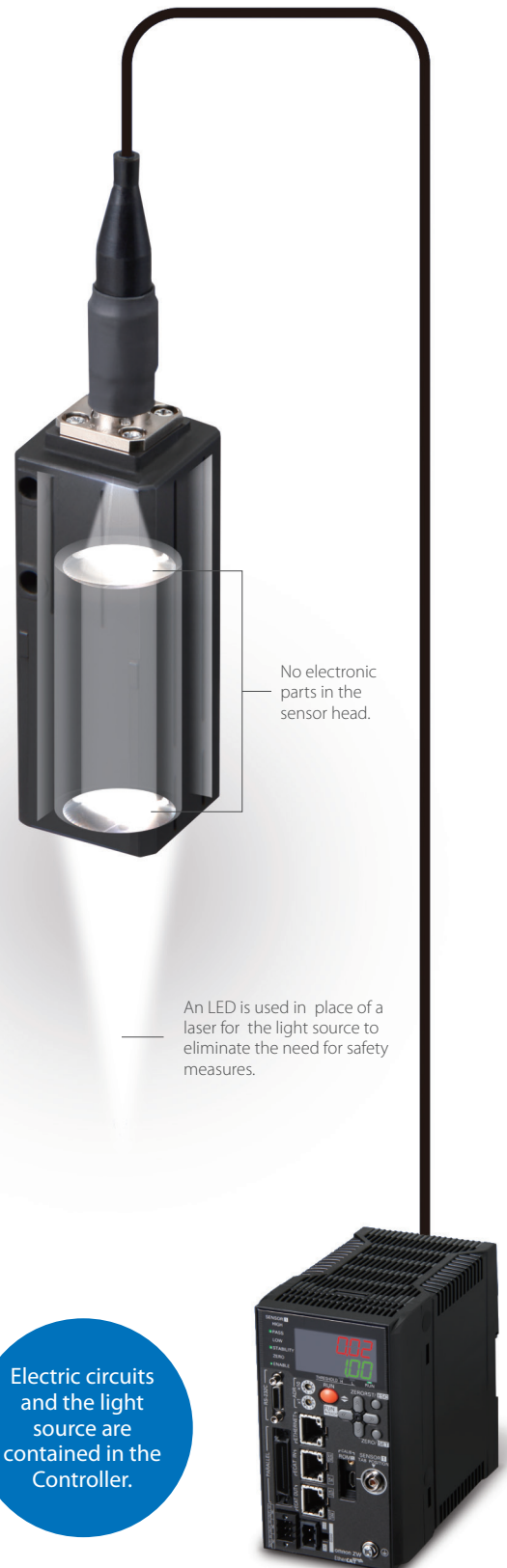
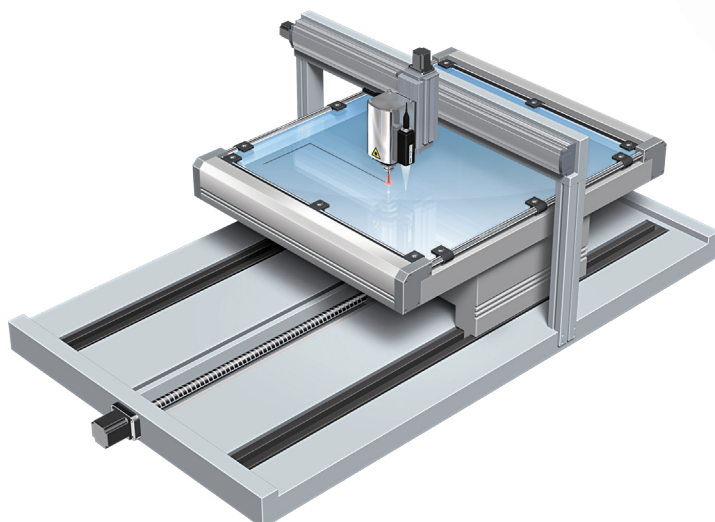

No electronic parts in the sensor head.

An LED is used in place of a laser for the light source to eliminate the need for safety measures.

Electric circuits and the light source are contained in the Controller.

N-Smart Series

Various Sensors Connected over EtherCAT

The N-Smart Lineup of Next-generation Fiber Sensors, Laser Sensors and Contact Sensors will quickly solve your problems and therefore increase equipment operation rates and minimize downtime with optimum cost performance.

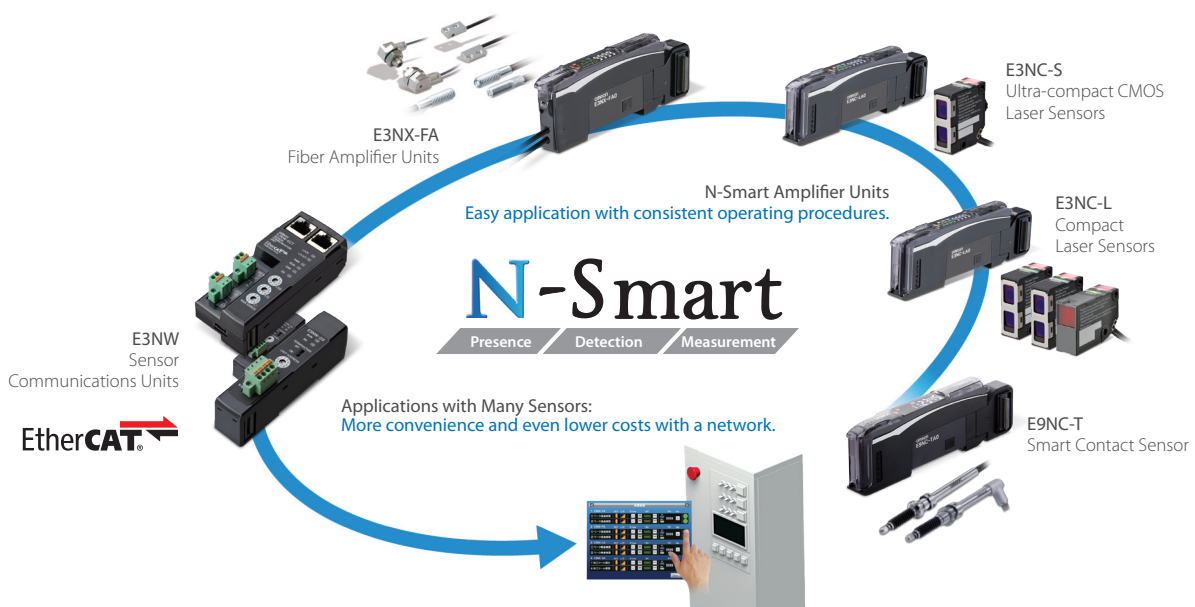

Features

- Ultra-easy Advanced Smart Tuning with the push of a button
- More stable detection of high-speed workpieces
- Predictive Maintenance to reduce downtime
- Highly visible white LED display
- E3NX-FA has 1.5x the sensing distance of conventional amplifiers

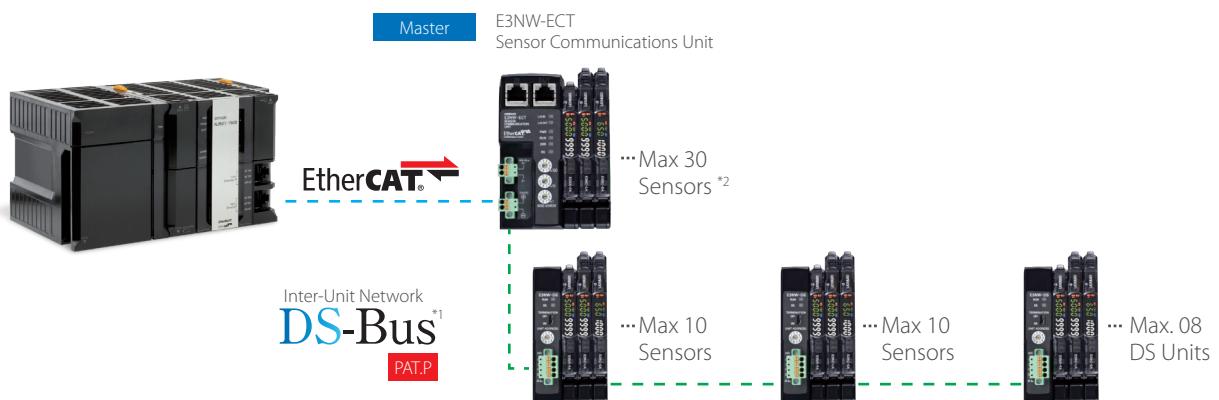

*1The DS-Bus is an OMRON inter-Unit network communications protocol, that connects the E3NW-ECT Sensor Communications Unit and E3NW-D5 Distributed Sensor Units.
 *2 Each E3NW Node supports a maximum of 30 total sensors, including DS-Bus sensors.

Service and support



OMRON technical offices across the World



Automation Center
Kusatsu (JPN), Shanghai (CHN), Barcelona (ESP),
Jakarta (IDN), Mumbai (IND), Chicago (USA)



Tsunagi laboratory
Kusatsu (JPN), Shanghai (CHN),
Den Bosch (NL), Mumbai (IND)



Technical office



Premium Partner

PRESENCE

COMPETENCE

OMRON

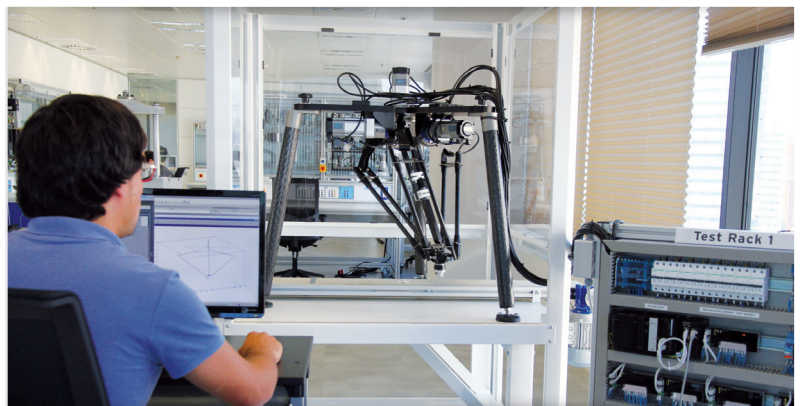

Design

Our wide network of machine automation specialists will help you to select the right automation architecture and products to meet your requirements. Our flat structure based on expert-to-expert contact ensures that you will have ONE accountable and responsible expert to deal with on your complete project.

Proof of concept

As your project matures make use of our Automation centers to test and catch-up with technology trends in motion, robotics, networking, safety, quality control etc. Make use of our Tsunagi (connectivity) laboratory to interface, test and validate your complete system with our new machine network (EtherCAT) and factory network (EtherNet/IP).

We will assign a dedicated application engineer to assist with initial programming and proof testing of the critical aspects of your automation system. Our application engineers have in-depth expertise in and knowledge of networks, PLCs, motion, safety and HMIs when applied to machine automation.



CONFIDENCE

ASSURANCE



Development

During your prototyping phase you will need flexibility in technical support, product supply and exchange. We will assign an inside sales contact to help you source the correct products fast during your prototyping phase.



Commissioning

With our world-wide network for service and support the export of your product is made simple, we will support you on-site with your customer, anywhere in the world. We can arrange a liaison sales engineer to facilitate training, spare parts supply or even machine commissioning. All this in a localised language with localised documentation – giving you complete peace of mind.



Serial production

As your production increases we will engage in supplying you within 24hrs and repairing within 3 days. All our products are global products meeting global standards - CE, cULus, NK, LR -

Sysmac family



MACHINE CONTROLLER				
Model	NX7	NJ5	NJ3	NJ1
Fastest cycle time	125 μ s	500 μ s	500 μ s	1 ms
Number of axes	256, 128	64, 32, 16	8, 4	2, 0
Task	Multi-tasking program			
Motion core	2 synchronized motion cores		Synchronized motion core	
Functions	<ul style="list-style-type: none"> Logic sequence Motion 	<ul style="list-style-type: none"> Logic sequence Motion Robotics Database Connection SECS/GEM 	<ul style="list-style-type: none"> Logic sequence Motion 	<ul style="list-style-type: none"> Logic sequence Motion
Software tool	Sysmac Studio			
Programming languages	<ul style="list-style-type: none"> Ladder Structured Text In-Line ST 			
Standard programming	<ul style="list-style-type: none"> IEC 61131-3 PLCopen Function Blocks for Motion Control 			
Program capacity	80 MB	20 MB	5 MB	3 MB
SD memory card	SD and SDHC memory card			
Built-in port	<ul style="list-style-type: none"> EtherNet/IP EtherCAT USB 2.0 			
EtherCAT slaves	512	192	192	64
Servo drive	Accurax G5/EtherCAT			
Motion control	<ul style="list-style-type: none"> Axes groups interpolation and single axis moves Electronic cams and gearboxes Direct position control for axis and groups 			
Robotics	--	Up to 8 Delta Robot control	--	--
Supported SQL servers	--	<ul style="list-style-type: none"> Microsoft SQL Server Oracle IBM DB2 MySQL Firebird 	--	--
Local I/O	-	CJ series units		
Remote I/O	NX I/O units/EtherCAT			
Mounting	DIN rail			
Global standards	CE, cULus	CE, cULus, NK, LR		
Ordering information	P072 Sysmac Catalogue - www.industrial.omron.eu/en/products/downloads			

MACHINE INTERFACE

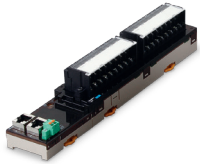

Model	NA5-15W	NA5-12W	NA5-9W	NA5-7W
Display	TFT colour LCD			
Display size	15-inch widescreen	12-inch widescreen	9-inch widescreen	7-inch widescreen
Resolution	1280 x 800 pixels		800 x 480 pixels	
Display colour	24 bit full colour			
Operator input	<ul style="list-style-type: none"> • Touch screen • 3 programmable function keys 			
Built-in port	<ul style="list-style-type: none"> • 2 x Ethernet • 3 x USB 2.0 			
Power requirements	19.2 to 28.8 VDC			
Software tool	Sysmac Studio			
IP ratings	Front panel IP65			
Memory card	SD and SDHC memory card			
Features	<ul style="list-style-type: none"> • Multiple-access level security with password protection • Visual Basic programming with VB.net • Integrated simulator in the Sysmac Studio 			
Options	Black and silver frame colours			
Ordering information	P072 Sysmac Catalogue · www.industrial.omron.eu/en/products/downloads			

I/O		
		
Model	NX Series I/O	GX Series I/O
Type	Modular I/O	Block I/O
Network specification	EtherCAT coupler unit	EtherCAT built-in
Number of units	<ul style="list-style-type: none"> Up to 63 I/O units Max. 1024 bytes in + 1024 bytes out 	Block I/O expandable with one digital I/O unit (16 points + 16 points)
I/O types	<ul style="list-style-type: none"> Digital I/O Analog I/O Encoder input Pulse output Temperature sensor input Safety control 	<ul style="list-style-type: none"> Digital I/O Analog I/O Encoder input Expansion unit
I/O connection	<ul style="list-style-type: none"> Screwless push-in terminals (All units) MIL connectors (Option for units with 16 and 32 digital I/O points) 	M3 screw terminals (1- or 3- wire DI)
Features	<ul style="list-style-type: none"> Automatic and manual address setting Standard and high-speed inputs Digital input filtering Removable push-in I/O terminals Synchronous I/O updates using Distributed Clock I/O units with Time Stamp function High signal density: 16 digital or 8 analog signals in 12 mm width 	<ul style="list-style-type: none"> Automatic and manual address setting High-speed input Digital input filtering Removable I/O terminals Expandable digital I/O
Mounting	DIN rail	
Ordering information	P072 Sysmac Catalogue · www.industrial.omron.eu/en/products/downloads	

SAFETY				
				
Model	NX safety controller	NX safety input unit	NX safety output unit	
Network specification	FSoE – Safety over EtherCAT			
Performance level	PLe (EN ISO 13849-1)			
Safety integrity level	SIL3 (IEC 61508)			
PFH	4.4E-10	3.80E-10	8.80E-10	
PFD	7.0E-06 (20 years)	6.6E-06	7.9E-06	
TM (Mission time)	20 years			
Programming	<ul style="list-style-type: none"> IEC 61131-3 standard 46 Safety FB/FUN 	–	–	
Safety connections	32 connections (NX-SL3300 safety CPU) 128 connections (NX-SL3500 safety CPU)	–	–	
I/O signal	–	<ul style="list-style-type: none"> 4 points 8 points 	<ul style="list-style-type: none"> 2 points 4 points 	
Number of test outputs	–	2	–	
I/O connection	Screwless push-in terminals			
Maximum load current	–	–	<ul style="list-style-type: none"> 2 A 0.5 A 	
Features	<ul style="list-style-type: none"> Freely mix with standard NX I/O Flexibility and reusability of the programming code Variables are part of the NX7/NJ controller project 	<ul style="list-style-type: none"> Freely mix with standard NX I/O High connectivity for direct connection to safety input devices I/O data monitoring in the NX7/NJ controller project 		
Mounting	DIN rail			
Ordering information	P072 Sysmac Catalogue · www.industrial.omron.eu/en/products/downloads			

SERVO SYSTEM



Model	Accurax G5 servo drive	
Type	Rotary servo drive	Linear servo drive
Ratings 230 V single-phase	100 W to 1.5 kW	200 W to 1.5 kW
Ratings 400 V three-phase	600 W to 15 kW	600 W to 5 kW
Applicable servomotor	Accurax G5 rotary motors	Accurax linear motors
Position, speed and torque control	EtherCAT	
Safety approvals	<ul style="list-style-type: none"> • PLd (EN ISO 13849-1) • SIL2 (IEC 61508) 	
Safety function	STO	
Full closed loop	Built-in	N/A
Ordering information	P072 Sysmac Catalogue - www.industrial.omron.eu/en/products/downloads	



Model	Accurax G5 rotary motor				Accurax G5 high inertia rotary motor		
Rated speed	3,000 rpm	2,000 rpm	1,500 rpm	1,000 rpm	3,000 rpm	2,000 rpm	1,500 rpm
Maximum speed	4,500 to 6,000 rpm	3,000 rpm	2,000 to 3,000 rpm	2,000 rpm	5,000 rpm	3,000 rpm	1,500 to 3,000 rpm
Rated torque	0.16 Nm to 15.9 Nm	1.91 Nm to 23.9 Nm	47.8 Nm to 95.5 Nm	8.59 Nm to 57.3 Nm	0.64 Nm to 2.4 Nm	4.77 Nm to 23.9 Nm	47.8 Nm
Sizes	50 W to 5 kW	400 W to 5 kW	7.5 kW to 15 kW	900 W to 6 kW	200 W to 750 W	1 kW to 5 kW	7.5 kW
Applicable servo drive	Accurax G5 rotary servo drive						
Encoder resolution	20-bit incremental/ 17-bit absolute		17-bit absolute	20-bit incremental/ 17-bit absolute		17-bit absolute	
IP rating	IP67				IP65	IP67	
Ordering information	P072 Sysmac Catalogue - www.industrial.omron.eu/en/products/downloads						

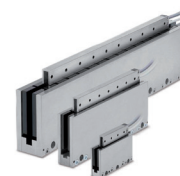

Model	Accurax linear motor	
Type	Iron-core linear motor	Ironless linear motor
Continuous force range	48 N to 760 N	29 N to 423 N
Peak force range	105 N to 2000 N	100 N to 2100 N
Maximum speed	1 to 10 m/s	1.2 to 16 m/s
Magnetic attraction force	300 N to 4440 N	Zero
Applicable servo drive	Accurax G5 linear drive	
Ordering information	P072 Sysmac Catalogue - www.industrial.omron.eu/en/products/downloads	

SERVO SYSTEM



Model	Integrated servo motor			
Rated torque	25 Nm	11,7 Nm	4,3 Nm to 5 Nm	2,55 Nm to 3,2 Nm
Frame size	190 mm	142 mm	100 mm	80 mm
Rated speed	3,000 rpm			
Maximum speed	4,000 rpm			
Encoder resolution	15-bit incremental/18-bit absolute			
IP rating	IP65			
Ordering information	P072 Sysmac Catalogue · www.industrial.omron.eu/en/products/downloads			

FREQUENCY INVERTERS



Model	RX	MX2
400 V three-phase	0.4 kW to 132 kW	0.4 to 15 kW
200 V three-phase	0.4 kW to 55 kW	0.1 kW to 15 kW
200 V single-phase	N/A	0.1 kW to 2.2 kW
Control method	Sensor-less and closed-loop vector control	
Torque features	<ul style="list-style-type: none"> • 200% at 0.0 Hz (CLV) • 150% at 0.3 Hz (OLV) 	<ul style="list-style-type: none"> • V/F control • Sensor-less vector control • 200% at 0.5 Hz
Connectivity	EtherCAT option board	
Logic Programming	Standard Firmware	
Customisation options	–	IP54 enclosure
Ordering information	P072 Sysmac Catalogue · www.industrial.omron.eu/en/products/downloads	

ROBOTS





Model	Accurax linear motor axis
Type	Linear motor axis
Continuous force range	48 N to 760 N
Peak force range	105 N to 2,000 N
Maximum speed	5 m/s
Magnetic attraction force	300 N to 4,440 N
Applicable servo drive	Accurax G5 linear drive
Ordering information	P072 Sysmac Catalogue - www.industrial.omron.eu/en/products/downloads





Model	Delta robot IP69K	Delta robot IP67	Mini Delta robot IP67	Mini Delta robot IP65
Type	Washdown Delta robot series			
Max. Payload	3 Kg		2 Kg	1 Kg
Degrees of freedom	3 + 1 (rotation optional)			
Rated working range	Ø 1,100 x 250 mm (Max. 400)	Ø 1,100 x 300 mm (Max. 450)	Ø 650 x 150 mm (Max. 250)	Ø 500 x 155 mm / Ø 450 x 135 mm (with rotational axis)
Cycle time	"25/305/25 mm (0.1 kg): Up to 150 cycle/ min"		"25/305/25 mm (0.1 kg): Up to 200 cycle/ min"	
Position repeatability	± 0.2 mm (X, Y, Z)		± 0.1 mm (X, Y, Z)	± 0.2 mm (X, Y, Z)
Angular repeatability	± 0.3° (q)	± 0.1° (q)		± 0.3° (q)
Protection class	IP69K	IP67		IP65 (Stainless steel + Titanium)
Rotational axis type	Shaft mounting	Tool Center Point mounting - Low or High inertia -	Tool Center Point mounting - Low or High inertia -	Shaft mounting
Option	-	Anti-collision detection	Anti-collision detection	-
Machine controller	NJ5 Robotics			
Servo drive	Accurax G5 rotary servo drive - EtherCAT			
Ordering information	P072 Sysmac Catalogue - www.industrial.omron.eu/en/products/downloads			



Model	Delta robot XXL	Delta robot XL	Delta robot	Mini Delta robot
Type	Delta robot series			
Max. Payload	8 Kg	2 Kg		1 Kg
Degrees of freedom	3 + 1 (rotation optional)			
Rated working range	Ø 1,600 x 350 mm (Max. 550)	Ø 1,300 x 250 mm (Max. 400)	Ø 1,100 x 250 mm (Max. 400)	Ø 500 x 155 mm / Ø 450 x 135 mm (with rotational axis)
Cycle time	"25/300/25 mm (8 kg): Up to 60 cycle/ min 200/1000/200 mm (8 kg): Up to 35 cycle/ min"	"25/305/25 mm (0.1 kg): Up to 120 cycle/ min"	25/305/25 mm (0.1 kg): Up to 150 cycle/ min	25/305/25 mm (0.1 kg): Up to 200 cycle/ min
Position repeatability	± 1 mm (X, Y, Z)	± 0.2 mm (X, Y, Z)	± 0.3 mm (X, Y, Z)	± 0.2 mm (X, Y, Z)
Angular repeatability	± 0.3° (q)		± 0.4° (q)	± 0.3° (q)
Protection class	IP65			
Rotational axis type	Shaft mounting			
Machine controller	NJ5 Robotics			
Servo drive	Accurax G5 rotary servo drive - EtherCAT			
Ordering information	P072 Sysmac Catalogue - www.industrial.omron.eu/en/products/downloads			

VISION		
		
Model	FQ-M	FH
Description	Designed for object tracking	Flexible machine vision
Interface	EtherCAT and Ethernet built-in	EtherCAT, Ethernet, USB and serial ports built-in, SD card
Inspection items	Shape search, search labelling, edge position	Over 100 processing items
Registered scenes	32	
Image processing method	Real colour or monochrome	
Camera resolution	752 x 480	4096 x 3072
Features	<ul style="list-style-type: none"> Fast and powerful object recognition Encoder input for object tracking and calibration Contour based object detection Sysmac Studio software for vision system operation and setting 	<ul style="list-style-type: none"> Powerful 4-core i7 parallel processor High speed CMOS camera Up to 8 camera by one controller Advanced shape search technology
Software	Sysmac Studio	
Supply voltage	24 VDC	
Digital I/O	9 in/5 out	17 in/37 out
Ordering information	P072 Sysmac Catalogue · www.industrial.omron.eu/en/products/downloads	

SENSING			
			
Model	ZW Series	N-Smart series	E3X/E3C/E2C
Type	Displacement sensor	Fiber/Laser/Contact sensor	Fiber/Laser/Proximity sensor
Measurement methods	White Light Confocal Fiber Principle	–	–
Applications	Height, thickness	–	–
Surfaces	Diffuse, shiny, mirror, glass, black rubber, metal, ceramics	–	–
Measurement range	<ul style="list-style-type: none"> Min: 7 ± 0.3 mm, Max: 40 ± 6 mm 	–	–
Resolution	0.01 µm to 0.25 µm	–	–
Linearity	± 0.8 µm to 7 µm	–	–
Special features	<ul style="list-style-type: none"> Ethernet built-in EtherCAT built-in RS-232C Analog VDC/mA Sysmac Studio 	<ul style="list-style-type: none"> High speed transmission of I/O-signals and incident values Up to 30 amplifiers on one communication unit Synchronized signal transmission Slave unit for decentralized machine installation 	<ul style="list-style-type: none"> High speed transmission of I/O-signals Up to 30 amplifiers on one communication unit
Network specification	–	EtherCAT communication unit	
Connectable sensors	–	Up to 30	
Amplifier types	–	<ul style="list-style-type: none"> E3NX-FA0 E3NC-LA0 E3NC-SA0 E9NC-TA0 	<ul style="list-style-type: none"> E3X-HD0 E3X-DA0-S E3X-MDA0 E3C-LDA0 E2C-EDA0
Mounting	–	DIN rail	
Ordering information	P072 Sysmac Catalogue · www.industrial.omron.eu/en/products/downloads		

SOFTWARE



Model Sysmac Studio

- The Sysmac Studio provides one design and operation environment for configuration, programming, simulation and monitoring
- One software for motion, logic sequencing, safety, vision and HMI
- Fully compliant with open standard IEC 61131-3
- Supports Ladder, Structured Text and In-Line ST programming with a rich instruction set
- CAM editor for easy programming of complex motion profiles
- One simulation tool for sequence and motion in a 3D environment
- Advanced security function with 32 digit security password
- PLCopen Function Blocks for Motion Control and Safety

Ordering information

P072 Sysmac Catalogue - www.industrial.omron.eu/en/products/downloads

ETHERNET AND ETHERCAT MEDIA



Model Ethernet switch

Number of ports

5

3

Functions

- QoS for EtherNet/IP
- Auto MDI/MDIX
- Failure detection: Broadcast storm and LSI error detection 10/100BASE-TX, Auto-Negotiation

- QoS for EtherNet/IP
- Auto MDI/MDIX

Power requirements

24 VDC (±5%)

Dimension

48 x 78 x 90 mm

25 x 78 x 90 mm

Mounting

DIN rail

Ordering information

P072 Sysmac Catalogue - www.industrial.omron.eu/en/products/downloads



Model EtherCAT junction slave (Branching unit)

Number of ports

6

3

Functions

- Power, Link/Act indicators
- Auto MDI/MDIX
- Reference clock

Power requirements

24 VDC (-15% to +20%)

Dimension

48 x 78 x 90 mm

25 x 78 x 90 mm

Mounting

DIN rail

Ordering information

P072 Sysmac Catalogue - www.industrial.omron.eu/en/products/downloads

Would you like to know more?

OMRON EUROPE B.V.

 +31 (0) 23 568 13 00

 industrial.omron.eu

Stay in touch

 twitter.com/omroneurope

 youtube.com/user/omroneurope

 linkedin.com/company/omron

Austria

Tel: +43 (0) 2236 377 800
industrial.omron.at

Belgium

Tel: +32 (0) 2 466 24 80
industrial.omron.be

Czech Republic

Tel: +420 234 602 602
industrial.omron.cz

Denmark

Tel: +45 43 44 00 11
industrial.omron.dk

Finland

Tel: +358 (0) 207 464 200
industrial.omron.fi

France

Tel: +33 (0) 1 56 63 70 00
industrial.omron.fr

Germany

Tel: +49 (0) 2173 680 00
industrial.omron.de

Hungary

Tel: +36 1 399 30 50
industrial.omron.hu

Italy

Tel: +39 02 326 81
industrial.omron.it

Netherlands

Tel: +31 (0) 23 568 11 00
industrial.omron.nl

Norway

Tel: +47 (0) 22 65 75 00
industrial.omron.no

Poland

Tel: +48 22 458 66 66
industrial.omron.pl

Portugal

Tel: +351 21 942 94 00
industrial.omron.pt

Russia

Tel: +7 495 648 94 50
industrial.omron.ru

South Africa

Tel: +27 (0)11 579 2600
industrial.omron.co.za

Spain

Tel: +34 902 100 221
industrial.omron.es

Sweden

Tel: +46 (0) 8 632 35 00
industrial.omron.se

Switzerland

Tel: +41 (0) 41 748 13 13
industrial.omron.ch

Turkey

Tel: +90 212 467 30 00
industrial.omron.com.tr

United Kingdom

Tel: +44 (0) 1908 258 258
industrial.omron.co.uk

More Omron representatives

industrial.omron.eu